



Professional Mixing Controller

OWNER'S MANUAL



VESTAX CORPORATION
2-37-1 Kamiuma, Setagaya-ku, Tokyo 154-0011 Japan
Phone 03-3412-7011 Fax 03-3412-7013

VESTAX MUSICAL ELECTRONICS CORPORATION
4240C South Mobile Circle, Aurora, Colorado 80015 U.S.A.
Phone 303-766-5269 Fax 303-766-2196
E-mail vestaxcorporation@msn.com

VESTAX (Europe) Ltd.
18 St. Christophers Road, Haslemere, Surrey GU 27 1DQ England.
Phone 01428-653117 Fax 01428-661021

CONGRATULATIONS!

Thank you for purchasing the VESTAX PMC-27MKII, Professional Mixing Controller. As The top of the line, the PMC-27MKII is a high specification mixer designed to meet the most professional requirements of the Dance Music DJ's.

Please read this owner's manual carefully before you start to use your mixer, so that you will fully understand all of the special features and enjoy the full of use of the product.

IMPORTANT

To prevent electric shock, do not remove the cover. No user serviceable parts are inside. Please refer servicing to a VESTAX Authorized Service Center. Always disconnect all equipment from the main supply when disconnecting or reconnecting signal leads. The power cord should be connected last. Make sure that the power switch is off when connecting the power cord. Disconnect from AC supply when equipment is not used for extended amount of time.

WARRANTY

The warranty might vary from country to country. Each distributor has their own warranty system in accordance with the country or state regulations or laws. VESTAX observes the manufacturing country's regulations.

PRECAUTIONS

- * Humidity and dust
Avoid use where there is high humidity and dust which may cause damage to internal parts.
- * Temperature
Avoid use in hot, (over 35°C) and cold, (below 5°C) locations. Keep the unit away from extreme direct heat such as direct sunlight, heating radiators, or closed vehicles.
- * Power cord handling
Connecting the power cord to other cords or joining cords together can cause fire and electric shock. This is extremely dangerous.
Take precaution when handling AC plugs and connectors.
Handle only the plug or connector and do not perform these operations with wet hands.
- * Keep away from liquids
Do not stand cans containing liquids on or near the equipment. If liquid enters equipment, disconnect the power cord from the power outlet immediately.

FEATURES

- Three band isolator switch kills each frequency range completely in quick action.
 - Pre / Post selectable AUX send switch enables various effect processing. The effect signal can be controlled by a dedicated return level control knob, the signal can be also monitored by headphone when "return" is selected by cue button.
 - The new option meter allows DJs to monitor the cue signal visually. The tempo can be matched by eyes as well as ears.
 - Three phono and 6 line inputs are provided to meet the new mixing style with various input source.
 - User replaceable 60 m/m input faders and 45 m/m cross fader make "on sight service" very easy. Optional input rotary volume can be replaced with the fader for "House" application.
 - Line 4 input jack (RCA) is located on the top panel. This allows DJs to use hand carried DAT or MD player mixing with installed equipment.
-

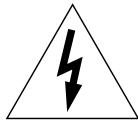

CAUTION

RISK OF ELECTRIC SHOCK DO NOT OPEN



CAUTION : TO REDUCE THE RISK OF ELECTRIC SHOCK
DO NOT REMOVE COVER (OR BACK)
NO USER-SERVICEABLE PARTS INSIDE
REFER SERVICING TO QUALIFIED SERVICE PERSONNEL

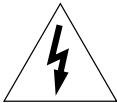

The lightning flash with arrowhead symbol, within an equilateral triangle, is intended to alert the user to the presence of uninsulated "dangerous voltage" within the product's enclosure that may be of sufficient magnitude to constitute a risk of electric shock to persons.



The exclamation point within an equilateral triangle is intended to alert the user to the presence of important operating and maintenance (servicing) instructions in the literature accompanying the appliance.

WARNING

TO REDUCE THE RISK OF FIRE OR ELECTRIC SHOCK, DO NOT EXPOSE THIS APPLIANCE TO RAIN OR MOISTURE.

CAUTION : TO PREVENT ELECTRIC SHOCK, MATCH BLADE OF PLUG TO WIDE SLOT, FULLY INSERT

ATTENTION : POUR EVITER LES CHOCs ELECTRIQUES, INTRODUIRE LA LAME LA PLUS LARGE DE LA FICHE DANS LA BORNE CORRESPONDANTE DE LA PRISE ET POUSSER JUSQU' AU FOND

IMPORTANT SAFETY INSTRUCTIONS SAVE THESE INSTRUCTIONS

WARNING : When using electric products, basic precautions should always be followed, including the following :

1. Read all the instructions before using the product.
2. Do not use this product near water - for example, near a bathtub, washbowl, kitchen sink, in a wet basement, or near a swimming pool, or the like.
3. This product should be used only with a cart or stand that is recommended by the manufacturer.
4. This product, either alone or in combination with an amplifier and headphones or speakers, may be capable of producing sound levels that could cause permanent hearing loss. Do not operate for a long period of time at a high volume level or at a level that is uncomfortable. If you should consult an audiologist.
5. The product should be location or position does not interfere with its proper ventilation.
6. The product should be located away from heat sources such as radiators, heat registers, or other products that produce heat.
7. The product should be connected to a power supply only of the type described in operating instructions or as marked on the product.
8. The power - supply cord of the product should be unplugged from the outlet when left unused for a long period of time.
9. Care should be taken so that objects do not fall and liquids are not spilled into the enclosure through openings.
10. The product should be serviced by qualified service personnel when ;
 - A. The power - supply cord or the plug has been damaged ;
 - B. Objects have fallen, or liquid has been spilled into the product ; or
 - C. The product has been exposed to rain ; or
 - D. The product does not appear to operate normally or exhibits a marked change in performance ; or
 - E. The product has been dropped, or the enclosure damaged.
11. Do not attempt to service the product beyond that described in the use - maintenance instructions. All other servicing should be referred to qualified service personnel.

TOP PANEL



PMC-27 MK II
PROFESSIONAL MIXING CONTROLLER

MICROPHONE
SUB INPUT SECTION

PROGRAM INPUT SECTION

MASTER
SECTION

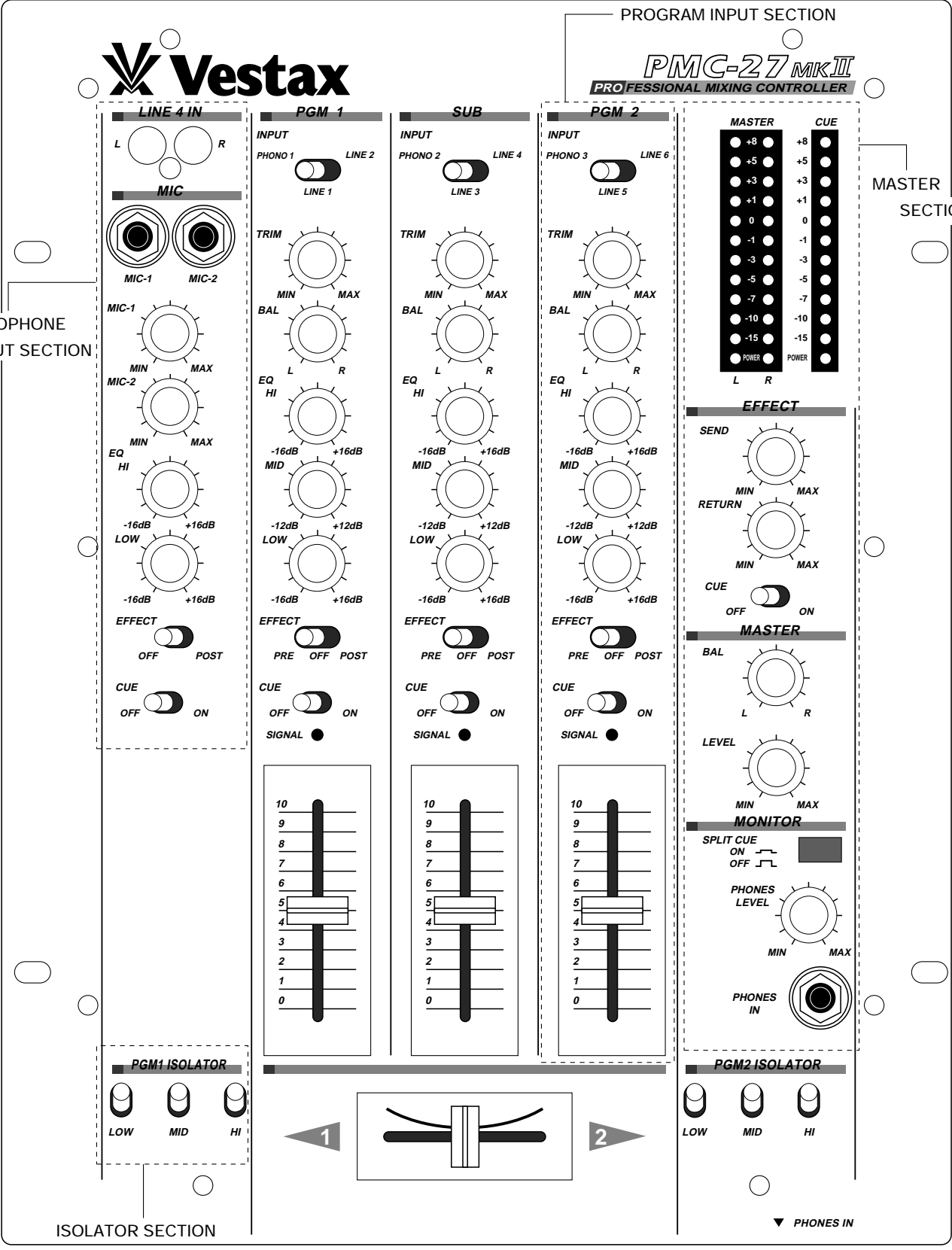

ISOLATOR SECTION

PHONES IN

PROGRAM INPUT SECTION

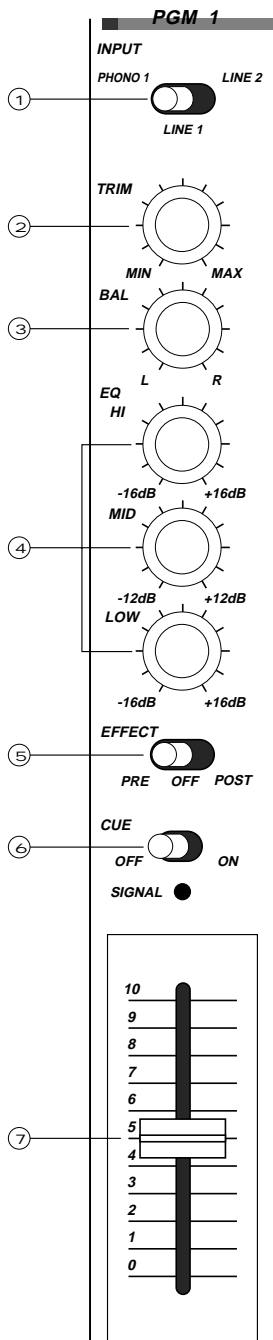

PROGRAM INPUT SECTION

1. INPUT SELECTOR

Used to select input (2line or 1phono) to be sent to each PGM channel.

2. TRIM CONTROL

Adjusts the Input level of each channel. Set INPUT FADER to 7-8 position. adjust TRIM so that the INPUT LEVEL METER shows about 0dB.

3. BALANCE CONTROL

Adjusts the stereo balance for each PGM channel. Can be used for adjusting the unbalanced stereo image caused by a strong anti-skating setting. Clockwise rotation from center position Increases the volume of R over L channel. A counter clockwise rotation Increases the volume of L channel over R.

4. EQUALIZER(HI,MID,LOW)

Adjusts the HI, MID, LOW frequencies for each PGM channel. Each band has following specifications.

HI	8kHz	±12dB	Shelving type
MID	500Hz	±16dB	Peaking type
LOW	80Hz	±12dB	Shelving type

5. EFFECT SWITCH

This switch enables the signal from each programs to be sent to AUX send jack. Different signal routes can be selected this switch to different positions.

PRE : The signal before the input fader (after the EQ) will be sent to AUX output.

POST : The signal after the input and cross fader will be sent to AUX output.

OFF : No signal will be sent to AUX output.

6. CUE SWITCH

Used to send the signal from each program to monitor section for headphone monitoring.

7. INPUT FADER

Used to adjust the Input level of each program. Usually set at the 7-8 position. This is a detachable fader for the ease of replacement. Replace with the IF-27 when It is worn out.

HOW TO REPLACE THE INPUT FADER

- Remove four screws which hold the fader unit panel.
- Take the unit out with the panel Carefully remove the multi-cable connector from the fader unit.
- Insert the connector to the new fader unit.
- Put the fader unit panel in position and tighten the screws.

8. CROSS FADER

When the Input level of PGM1 and PGM2 are properly set, PGM1 will be heard with the cross fader set to the left side. PGM2 will be heard with the cross fader set to the right side. When the cross fader is set in the center, both programs will be heard. This is detachable fader for the ease of replacement with CF-R when it is worn out.

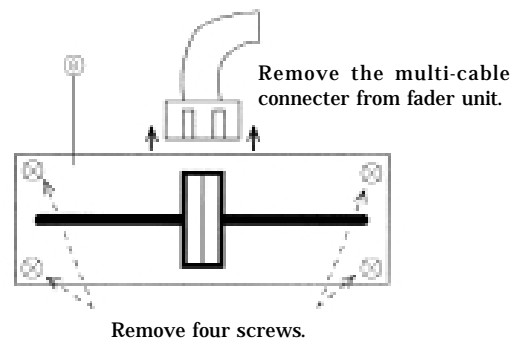
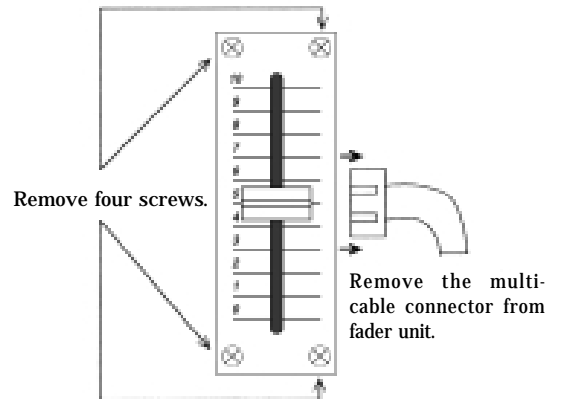

MICROPHONE, SUB INPUT SECTION

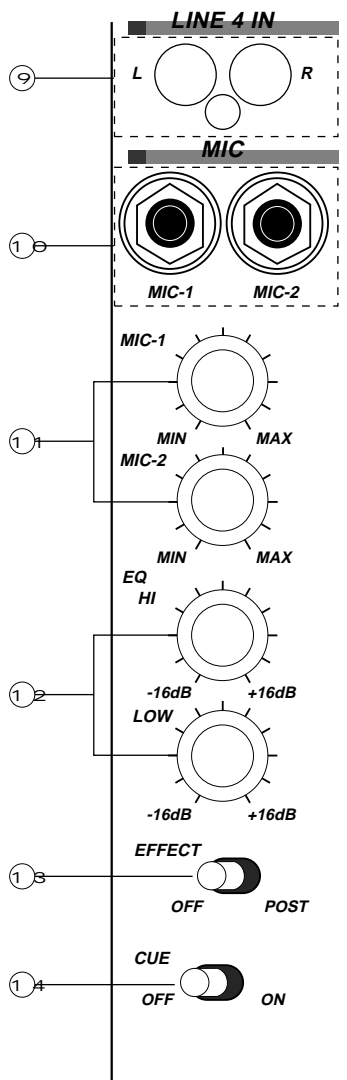

MICROPHONE, SUB INPUT SECTION

9. **LINE INPUT JACK(LINE4)**
Input connectors for line level equipment such as CD players,tape decks ,DATs, or MDs ETC.
10. **MIC INPUT JACK(MIC1,2)**
Input jacks of mic1, mic2.
11. **MIC LEVEL**
Adjusts the input level from all of the microphone inputs.
12. **MIC EQUALIZER(HI,LOW)**
Adjusts the HI and LOW frequencies for all of the microphone input.
13. **EFFECT SWITCH**
Used when sending signal to the external effect processor connected to the effect SEND/RETURN.
14. **CUE SWITCH**
Used to send the signal from the mic channel to the monitor section for head phone monitoring.

MASTER SECTION

15. **MASTER OUT LEVEL METER**
The LED level meters indicate the signal level of the line out.
16. **CUE LEVEL METER**
The LED level meters indicate the signal level of PGM input selected by CUE SWITCH.
17. **EFFECT SEND LEVEL**
Used to adjust the output level from EFFECT SEND JACK. The signal is selected by the effect switch.
18. **EFFECT RETURN LEVEL**
Used to adjust the input level from the EFFECT RETURN JACK. This EFFECT RETURN can be used as the sub line input.
19. **EFFECT CUE SWITCH**
Used to send the signal from EFFECT RETURN JACK to the monitor section for headphone monitoring.
20. **MASTER BALANCE VOLUME**
Adjusts the signal balance of left to the right side of the outputs from the OUTPUT jack on the rear panel.
21. **MASTER LEVEL VOLUME**
Adjust the signal level output from the OUT PUT jack on the rear panel.
22. **SPLIT CUE SWITCH**
When this switch is ON, the master signal is always heard through the right earcup of the headphone. The CUE signal will be heard in the left earcup when that input is selected by the CUE SWITCH (5, 14). This enables both programs to be monitored simultaneously,thus assisting in beat mixing.
23. **HEAD PHONE LEVEL**
Adjusts the headphone output level.
24. **HEAD PHONE JACK**
Use this jack to connect the headphones the inopdance 8ohm to 600ohm can be used, 150ohm is recommended.

MASTER SECTION

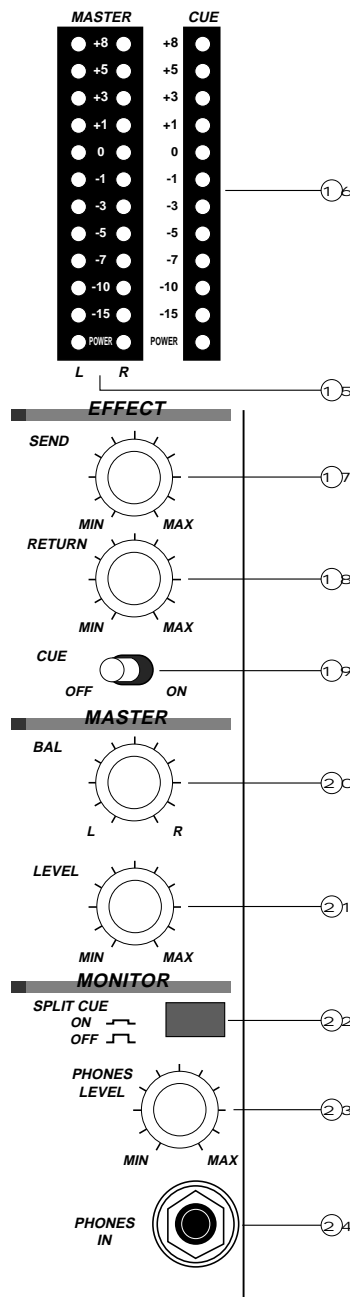

ISOLATOR SECTION

25, HI SWITCH

Allows cutting off the sound of treble range. Sound volume will be cut when the switch is set downwards. When the switch is put back, the output volume returns to normal. Can be useful for cutting off the sound of the cymbals or high hats for example.

26, MID SWITCH

Allows cutting off the sound of the middle range. Sound volume will be cut when the switch is downward position. When the switch is put back, the output volume becomes normal sound volume. Can be used for cutting off vocal and melody from the source.

27, LOW SWITCH

Allows cutting off the sound of the bass range. Sound volume will be cut when the switch is set downward. When the switch is put back, the output volume return to normal. Can be utilized for creating the effects of an acapella.

ISOLATOR SECTION

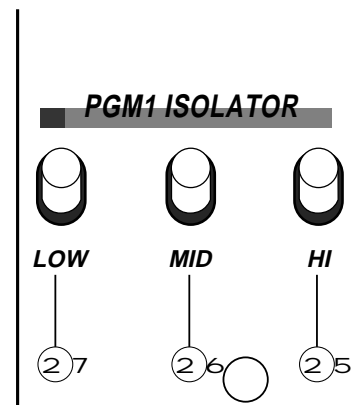

REAR PANEL

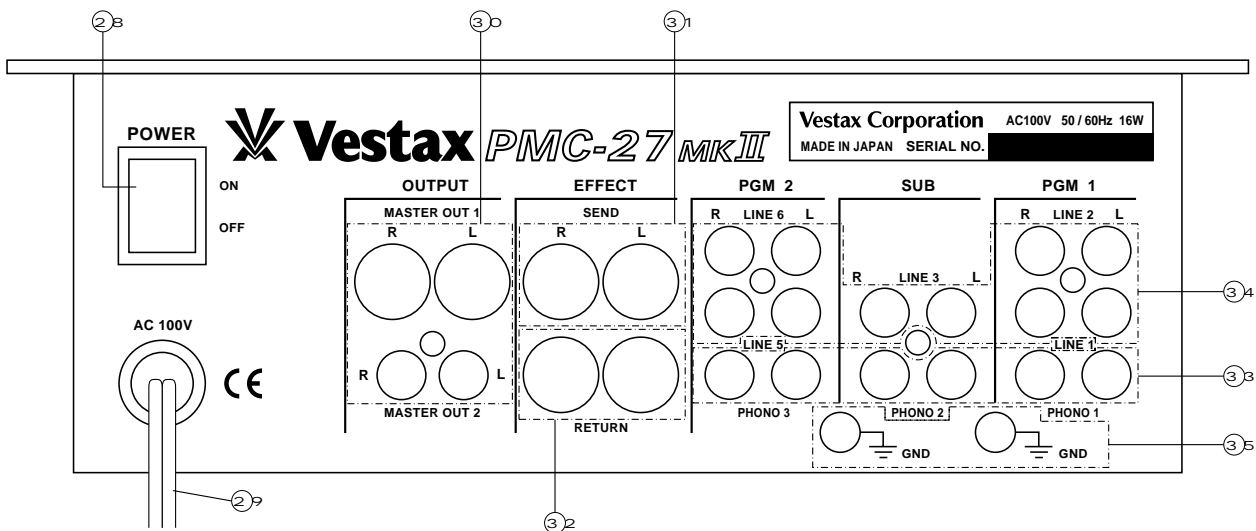

REAR PANEL

28. POWER SWITCH

The first LED of MASTER OUT LEVEL METER that is located on the top panel is lit when on.

29. AC POWER CABLE

30. OUTPUT JACK(1/4inch PHONE JACK, RCA PIN JACK)
Connect to the input of power amplifier.

31. EFFECT SEND JACK

Connect the SEND jacks to the input of an external effector unit(Delay,Reverb etc)

32. EFFECT RETURN JACK

Connect the RETURN jacks to the output of the effector.

33. PHONO INPUT JACK

Input jack for PGM1,PGM2 and SUB channel turntables.

Connect turntables equipped with the MM pick up certridge only.

34. LINE INPUT JACK

Input connectors for the line level equipment such as CD players, tape decks, DATs, MDs.

35. GROUND TERMINAL

Connect this terminal to the ground lead of the turntable. This helps to reduce noise and hum.

